

---

# Behaviour of Unreinforced R.C. Beam-Column Joints Under Bidirectional Loading

*A. Moshref, I. Palmer*

Miyamoto International NZ, New Zealand

*M. Khanmohammadi, M. Katrangi*

School of Civil Engineering, College of Engineering, University of Tehran, Iran

## ABSTRACT

Modern building codes for reinforced concrete (RC) frame structures in areas susceptible to earthquakes prescribe detailing requirements for the beam-column joint to prevent shear failure and subsequent loss of gravity support. Most RC frame buildings in New Zealand constructed pre-1960s have unreinforced beam-column joints. These structures are also typically reinforced with plain bars which are susceptible to bond failure which degrades the strength and deformation capacity of the joint. Current MBIE/NZSEE guidance to assess the deformation and strength of unreinforced beam-column joints is typically conservative compared to alternative assessment guidance (e.g., ASCE41-17), especially for exterior joints and even more so when the beam longitudinal bars terminate in 180-degree hooks. There is also has limited guidance on the effect of bidirectional loading.

This paper investigates bidirectional cyclic testing on a 70% scaled beam-column joint based on a 1930s building in Wellington, NZ. The joint is an exterior corner joint with plain column and beam longitudinal reinforcing and beam longitudinal bars terminating with 180° hooks.

## 1 INTRODUCTION

Beam column joints are one of the key elements in the seismic load carrying capacity of reinforced concrete structures. Current seismic codes prescribe detailing requirements and a capacity design approach to prevent joint failure due to forces acting on the beams and columns. Based on this approach, the shear capacity is required to be greater than maximum shear force that could develop in the joint. To ensure adequate stability in shear, joints are required to be reinforced with lateral confinement reinforcing steel.

Assessing joint behaviour becomes complicated where joints were designed following previous design codes which do not prescribe the same detailing and capacity design requirements as modern codes. The main deficiencies include the use of plain bars, inadequate development length, hook detailing, lack of confining

shear reinforcement, inadequate shear strength, and joint dimensional ratios. Due to these deficiencies, the seismic assessment of joint behaviour can be a challenging issue.

The American design standard “Seismic Evaluation and Retrofit of Existing Buildings (ASCE 41-17)” (ASCE 2017) attributes a displacement-controlled behaviour for all joints, including exterior or interior. The standard dictates the shear capacity of joints should be determined following ACI approaches and modified using a  $\gamma$  value detailed in Table 10-12 of ASCE 41-17. The nonlinear behaviour of the joint depends on the axial load ratio, conforming or non-conforming transverse reinforcement, and the shear demand ratio. In this method there is no explicit consideration given for hooked deformed or plain bars.

The New Zealand Engineering Assessment Guidelines Section C5 Concrete Buildings (NZSEE Revised C5 2018) (NZSEE 2018) accounts for the anchorage detailing by reducing the shear capacity of the beam-column joint depending on the anchorage detailing and curvature ductility demand by applying a joint shear coefficient,  $k_j$  (Figure 1).

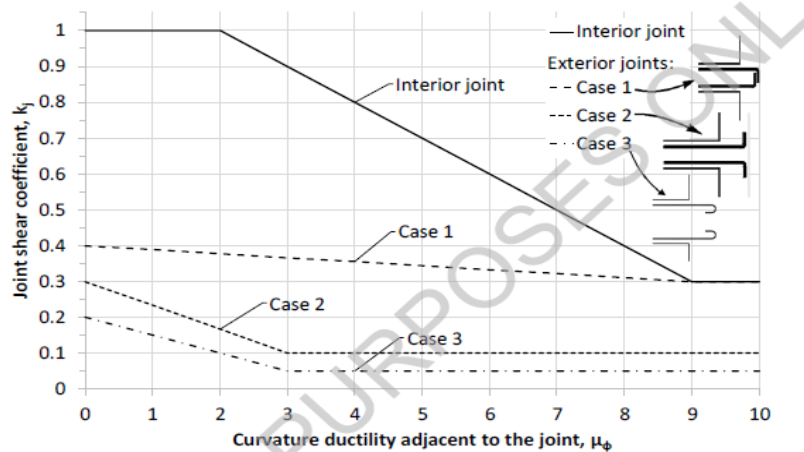

Figure C5.27: Joint shear coefficient,  $k_j$ , for different joint geometries

Figure 1:  $K_j$  used for calculation of maximum tensile stress at joints (NZSEE 2018)

The NZSEE recommended values for  $k_j$  are based on experimental testing completed by Hakuto et al. (Hakuto 1995) (Hakuto 1999) (Hakuto 2000), which predominantly focused on deformed bars with no variation of axial load, and Pampanin et al. (Pampanin 2002) (Pampanin 2003), which predominantly focused on plain bars and variation of axial load. For both experimental tests, the specimens were based on small beam-column assemblies and did not include the effects of a concrete slab.

For bi-axial actions and their effects of joints behaviour, NZSEE Revised C5 2018 suggests a further reduction in shear capacity of 30%. ASCE 41-17 does not contain a recommendation to account for bi-axial effects on joint shear capacity.

This study investigates bidirectional cyclic testing on a 70% scaled beam-column joint based on a 1930s building in Wellington, NZ. The joint is an exterior corner joint with plain column and beam longitudinal reinforcing and beam longitudinal bars terminating with 180-degree hooks.

## 2 EXPERIMENTAL PROGRAM

### 2.1 Prototype and Specimen Configurations

29 Waterloo Quay, Pipitea, Wellington, is a seven-storey reinforced concrete frame building constructed circa 1935. The buildings current use is as a hotel and backpackers. The total height of the structure is approximately 24m above foundation level. A detailed seismic assessment (DSA) revealed the main characteristic that limits

*Paper 81 – Behaviour of Unreinforced R.C. Beam-Column Joints Under Bidirectional Loading*

the structural rating of the building is the inadequate beam-column joint shear capacity, particularly exterior column joints. The assessment identified the joints as deficient due to the hooked plain bar reinforcing, identified in the original construction drawings (Case 3 from Figure 1).

The plain (undeformed) bars are prone to sliding when the bond between the steel and concrete fails. The 180-degree hooks result in concrete crushing at the hook ends as the bars slide causing shear failure at the joint and likely loss of axial load carrying capacity.

The exterior column joints were initially assessed following the NZSEE Revised C5 Guidelines. Given the reinforcement configuration and high curvature ductility demand on the structure, the joint shear coefficient reduces to 0.05 (Figure 1). Applying a further 30% reduction for biaxial actions, reduces the joint shear capacity to nearly zero.

Following a review of the literature behind the NZSEE guidelines and the size of testing, the consensus was the conclusions from these tests may be overly conservative when applied to large beam-column joints and further testing will provide valuable information on actual joint behaviour.

A corner beam-column subassembly at Level 4 was selected as the worst-case representative beam-column joint compatible with the structural lab equipment and facilities. Figure 2 shows the selected prototype beam and column.

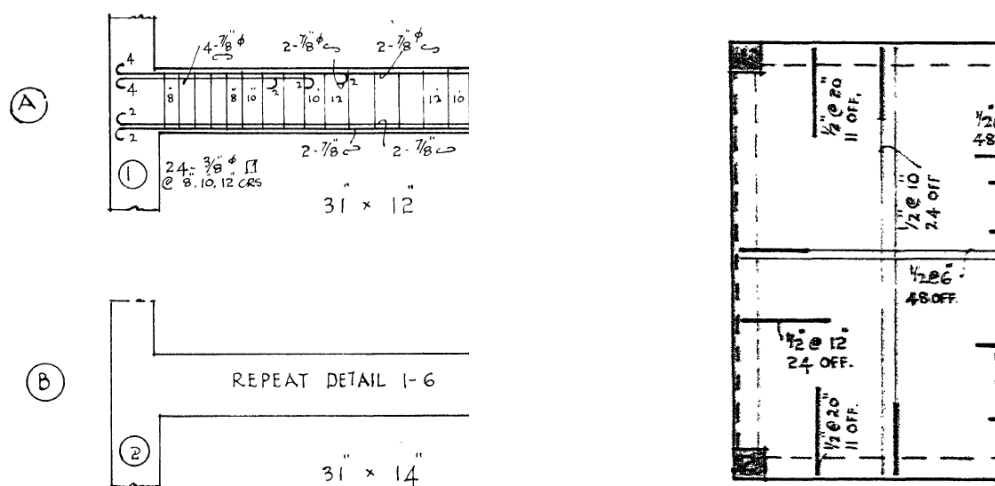
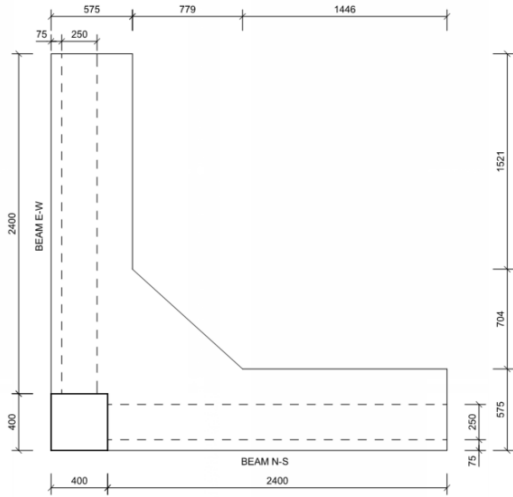

Figure 2: View of selected prototype and reinforcements left: rebars of beam, right: slab reinforcement.

The test specimen was designed to represent the prototype design, scaled to 70% of the actual size. Figure 3 illustrates the test specimen as designed. The specimen was constructed to the halfway point of the beam span and column storey height. Since the test was to study joint behaviour only the portion of the slab that would influence behaviour was included in the model as the full effective width would add weight, increase construction complexity and potentially cause torsion on the joint.

The prototype reinforcement was specified based on the ratio in the original construction. The reinforcement ratio was scaled by reducing the diameter of the bar while keeping the same number of bars after initial attempts to replicate both bar diameter and detailing were limited by bar development lengths. Figure 4 shows a general arrangement of test specimen reinforcement.



a) Plan

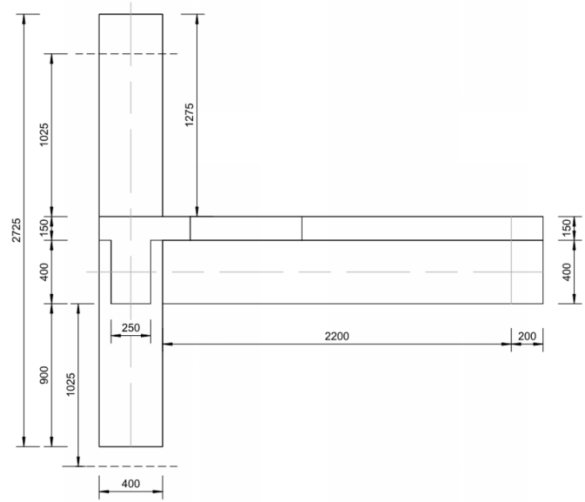

b) Side Elevation

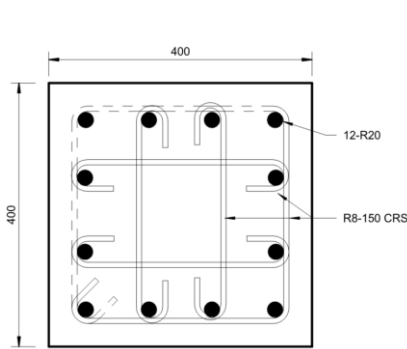

c) Column Section

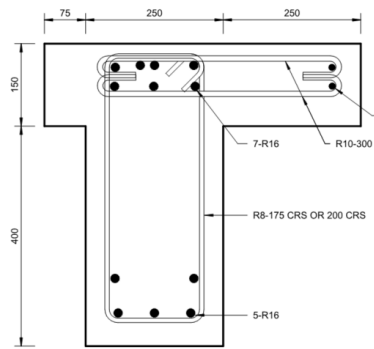

N-S BEAM SECTION

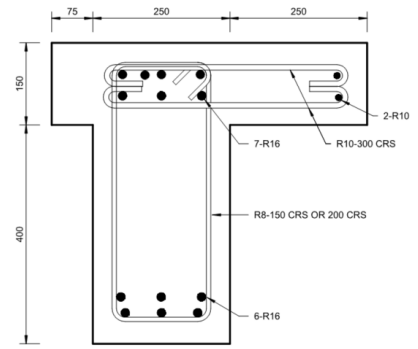

E-W BEAM SECTION

d) Beam Section

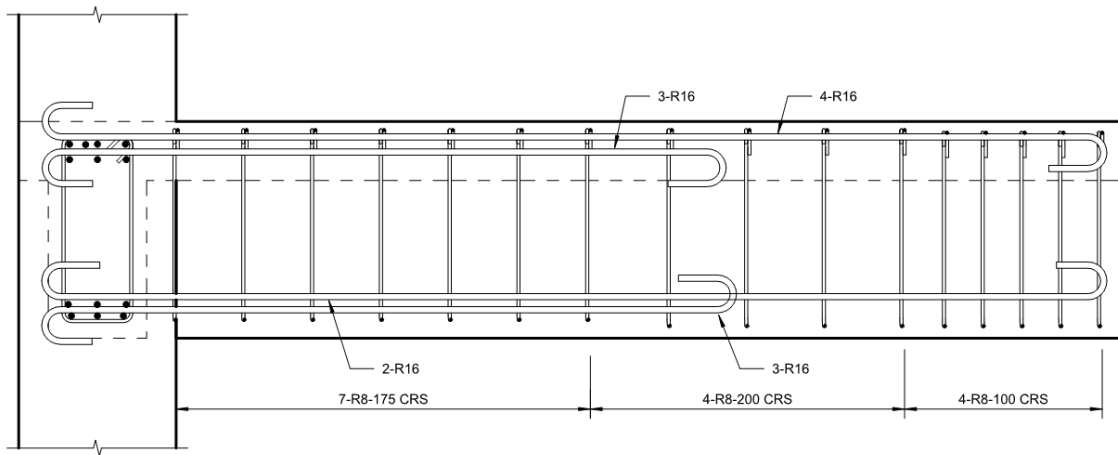

Figure 3: Reinforcing and geometry details of the specimen.



Figure 4: Longitudinal and transvers reinforcing of the specimen.

## 2.2 Test Setup and Loading Protocol

Figure 5 illustrates the schematic test setup and loading system. In this setup, the columns were hinged at the base to simulate inflection points in a real frame subjected to lateral loading. The column was loaded using two orthogonal horizontal actuators with capacities of 250kN and 100kN and strokes of  $\pm 125\text{mm}$  and 400mm, respectively. The loading was controlled by displacement for the two actuators and applied simultaneously.

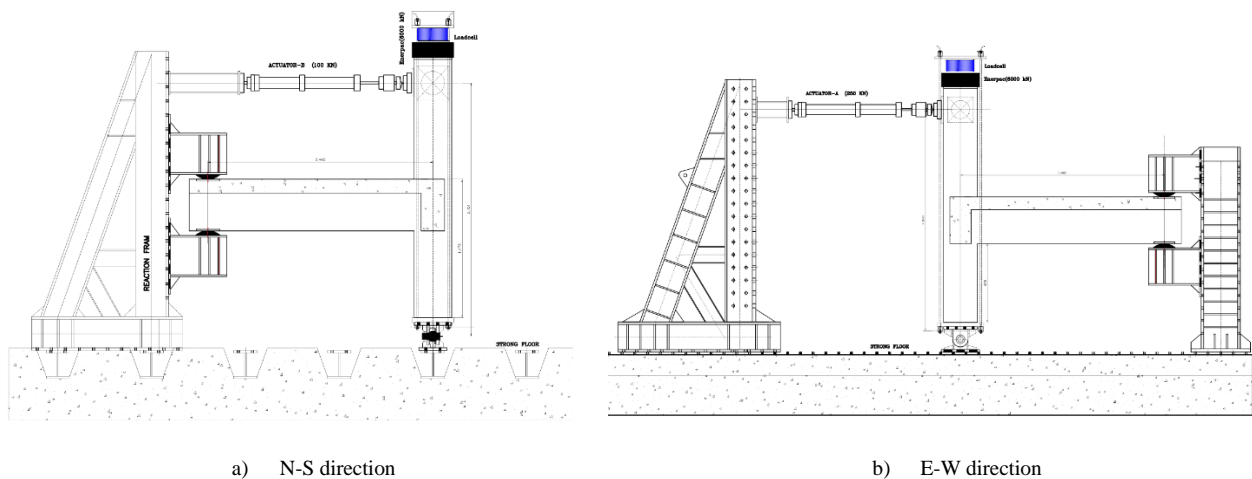

Figure 5: Test Setup

An axial load ( $P$ ) was applied to each specimen, representing an axial load ratio of  $0.13A_g f'_c$  (650kN). A vertical hydraulic jack with a capacity of 6000kN was used to apply the axial load to test specimens, and the axial load was kept constant during the lateral loading. To this end, four 0.6" mono-strand cables were implemented to connect the top and bottom sole plates. A loadcell with 1000 kN capacity was arranged on top of the column, between the vertical jack and top sole plate. Due to the mechanism for axial loading,  $P-\Delta$  effects on the specimen behaviour was not considered.

A 3-dimensional hinge was designed to accommodate hinge rotation along the two horizontal directions at the base of column. Since the loading is bi-directional, the boundary condition at the beam end should be unrestrained in the two horizontal orthogonal directions and restrained in vertical direction. Therefore, a sliding mechanism was designed to transfer the vertical reactions and mitigate any torsional restraint at the end of beams. Embedded plates were included in the set up to mitigate this movement.

To investigate the bond stress for the reinforcing bars, slippage of bars at joint region, and the influence of end hooks on behaviour, 20 strain gauges were installed on each specimen. These were placed in the top and base beam and column reinforcement. All strain gauges were post yield YEFLA-5 gauges, manufactured by TML. To record the displacements and deformations of beams, columns, and joint shear distortion, 14 linear variable differential transformers (LVDT) were installed on different parts of each specimen to record beam and column deformation and joint shear distortion. Figure 6 shows a schematic of the strain gauges and LVDTs.

As shown in Figure 6, two LVDTs were installed at the top and base of each beam at the face of columns to measure the slippage of rebars through the joint region, which is expected to happen once cracks open. Four LVDTs were arranged at each column face to measure joint displacements (shear deformations). Other LVDTs were placed to measure general displacement at different parts of the specimen.

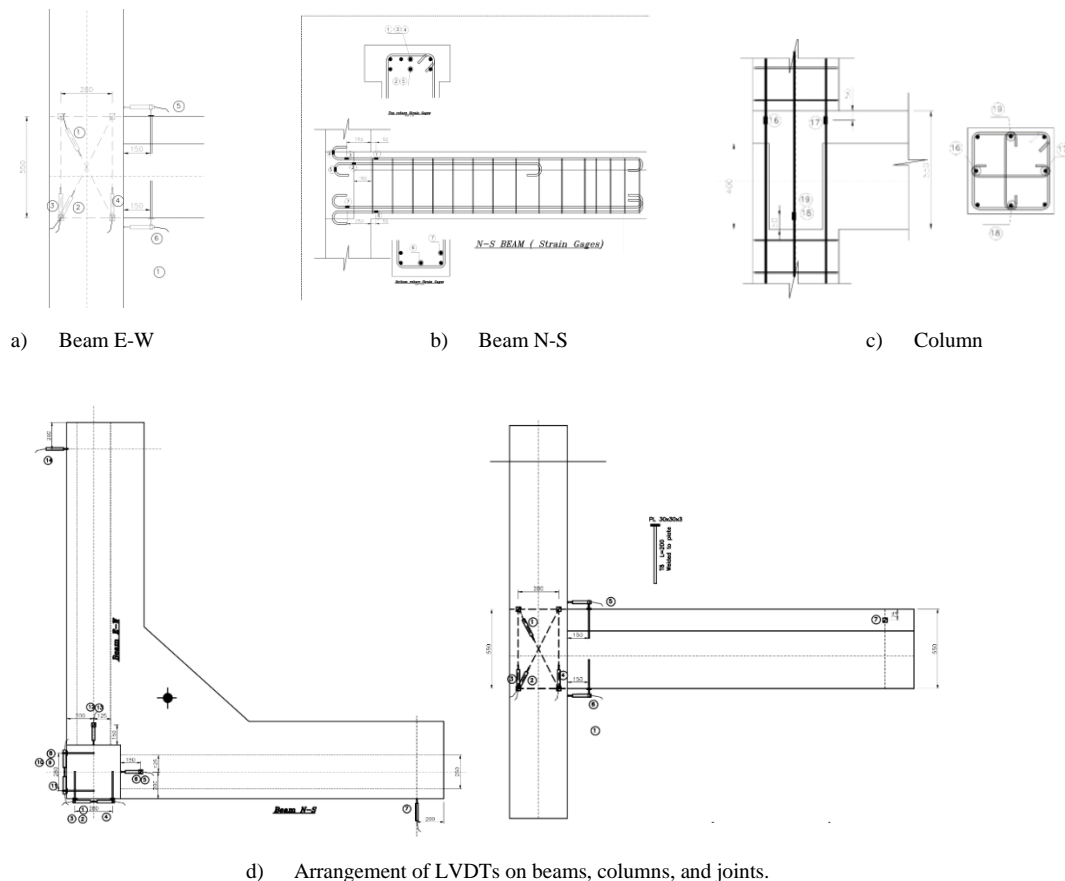

*Figure 6: Arrangement of Strain Gauges*

### 2.3 Loading Protocol

In general, the loading protocol should reflect the characteristics of the typical hazard for a region. To better reflect the site hazard, the use of hazard-consistent ground motions is more desirable and specific characteristics of the earthquake records, such as amplitude/intensity of shaking, ground motion duration, pulse effects and soil type, should be considered as part of the loading definition (Francesco and Sullivan 2021).

It is important to consider the sensitivity of different possible failure mechanisms to loading protocol when selecting a site-specific loading protocol. This aspect may be particularly relevant for bidirectional loading protocols. A bidirectional loading protocol that is characterized by equal displacement demand in both the directions of testing could be un-conservative for a specific failure mechanism relative to a loading protocol that imposes higher displacement demands in one direction than the other. This is because cracking and non-linear deformations that occur due to demand in one direction may affect the loading and deformability in the orthogonal direction (Francesco and Sullivan 2021).

Raza et al. (Raza 2019) proposed different loading protocols for bidirectional loadings, as is shown in Figure 7. Recent studies suggest that the ratio between the peak displacement demands in the two main orthogonal directions ( $a/b$ ) depends on the local seismic hazard.

Francesco et al. (Francesco and Sullivan 2021) emphasized the number of cycles of demand at different amplitudes, in the different testing directions, may also affect the capacity of a structure and this should be considered further as part of the development of future loading protocols.

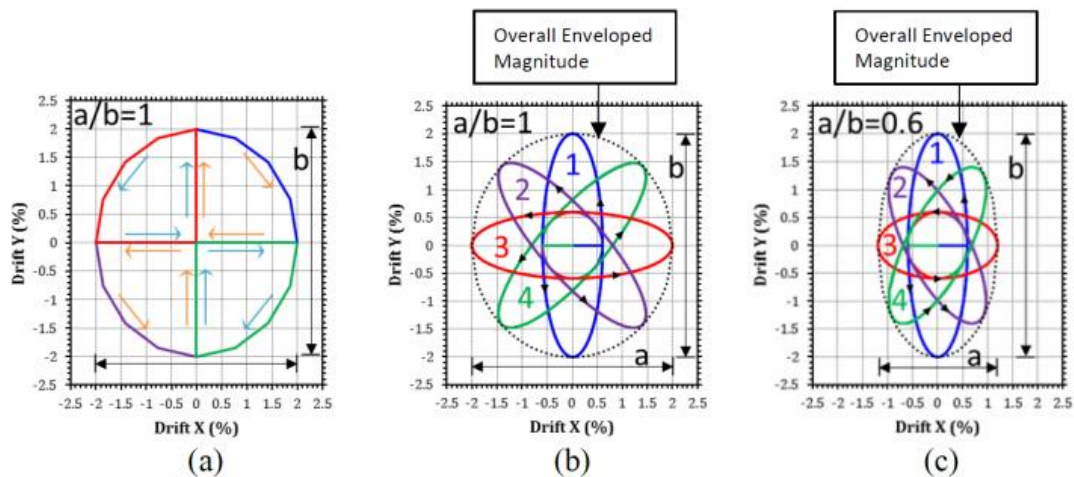

Figure 7: Loading protocols proposed by Raza et al. for bidirectional loading (Raza 2019)

In another research, two different tests on the damageability of hollow-core floors have been reported by Bueker et al. (Bueker 2022). In these, two different loading protocols were used: a circular bidirectional loading and octo-elliptical loading pattern with an aspect ratio of 0.5.

Considering the above information, we considered the approach reported in Bueker et al (Bueker 2022) to be reasonable. Therefore the test was carried out using an octo-elliptical path with ratio of displacement demand in the main directions of 0.5 and the number of cycles as reported by Bueker et al (Bueker 2022).

## 3 TEST RESULTS AND DISCUSSION

The damage and cracking patterns observed at the end of selected peak inter-storey drifts,  $\theta_{\text{drift}}$  is shown in Figure 8. The testing was stopped at 2.5% lateral drift due to safety concerns after significant joint damage.

The main observed damage is as follows:

*Paper 81 – Behaviour of Unreinforced R.C. Beam-Column Joints Under Bidirectional Loading*

- Flexural cracking of beams along span as well at the face of the column at 1.5% drift.
- Opening of beam cracks at the face of the column resulting bar slip through the joint and beam length from the 0.5% drift ratio up to the end of test.
- Diagonal cracking of the joint in the E-W direction forming at 1% drift and opening up to 3mm at 2% drift.
- Swelling of concrete cover at the joint face observed at 2% drift.
- Spalling of concrete at the face of joint in N-S direction observed at 2% drift

Based on the NZSEE Revised C5 Guidelines, we would expect the joint to rapidly degrade under biaxial loading and to fail under relatively low levels of drift. The test results showed the joint displayed significantly better performance, maintaining joint shear stability and axial load carrying capacity even after cracks form.

For this case, the NZSEE guidelines were overly-conservative in their predictions for joint response on a large specimen.

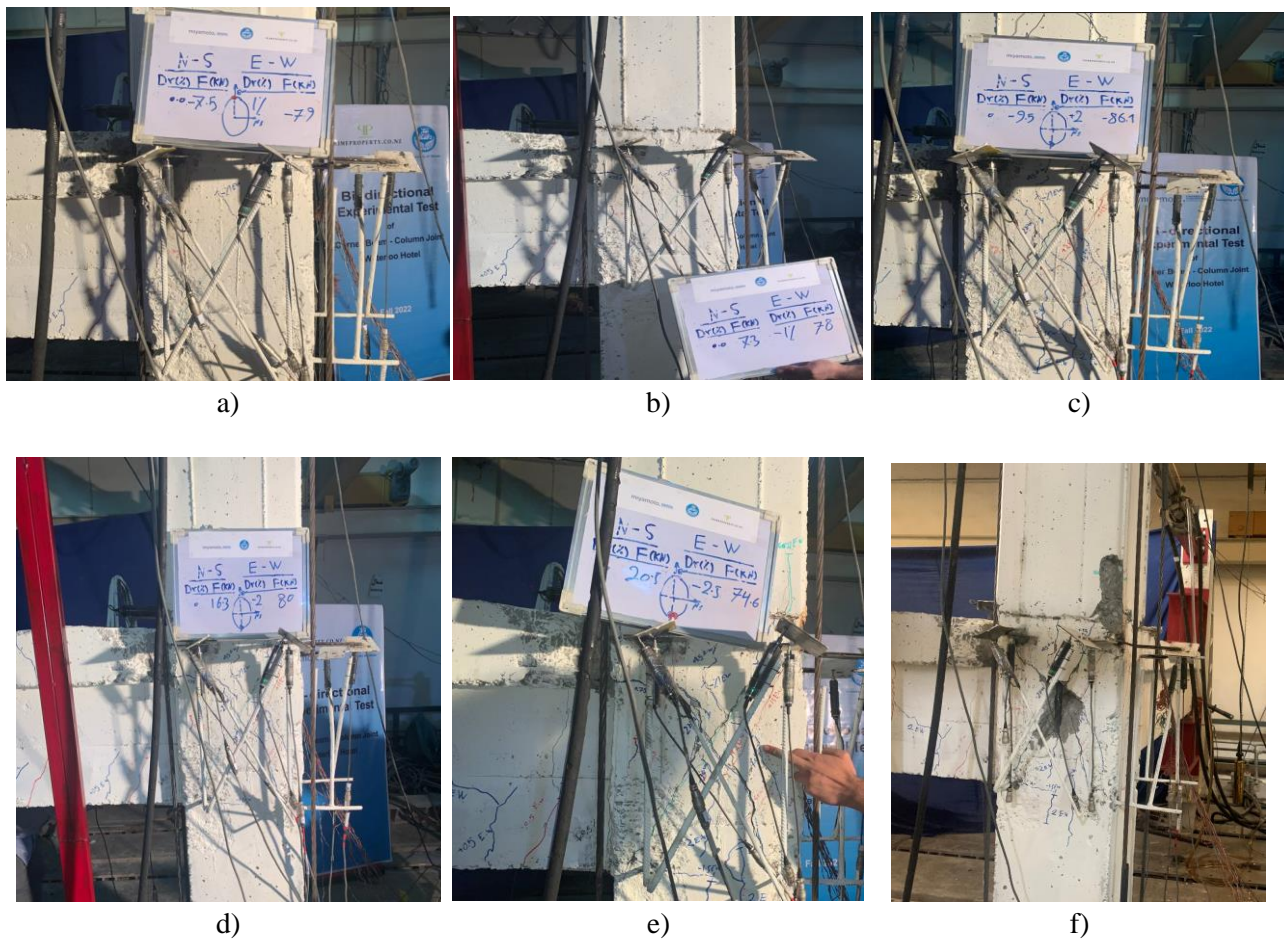

Figure 8: Observed cracking pattern of E-W cycle of a) +1.0%; b) -1.0%; c) +2.0%; d) -2.0%; e) +2.5%; and f) end of test

**Error! Reference source not found.** shows the force-displacement hysteresis plot for the specimen. Strength degradation occurred at 2.5% drift ratio due to joint shear degradation. The main shear crack of joint opened more than 3 mm at this drift.



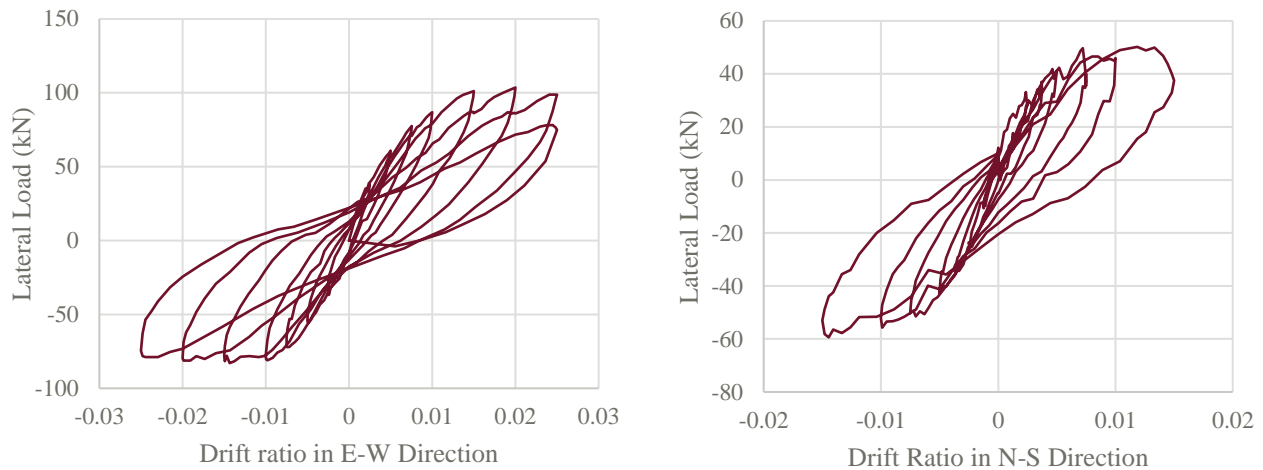

Figure 9: To column lateral force versus drift, left) E-W direction, right) N-S direction.

## 4 CONCLUSIONS

The seismic performance of a 1930s exterior beam-column joint reinforced with plain bars and 180-degree hooks has been investigated using bi-directional quasi-static testing. Assessing joints which do not conform to modern codes is a challenging issue and current assessment guidelines provide limited guidance on the bi-axial actions and their effect on joint behaviour. Assessment following the NZSEE Revised C5 Guidelines resulted in nearly zero joint shear capacity.

The bidirectional test results on the large-scale specimen indicates better performance for joint responses compared to the guidance in the NZSEE Revised C5.

Further investigation is required to provide refined guidance on non-conforming joint behaviour and to the sensitivity of failure modes to different bi-directional loading protocols.

## 5 ACKNOWLEDGMENT

The financial support provided by PrimeProperty Group Ltd. through the strengthening of Waterloo Hotel is greatly acknowledged.

## REFERENCES

- ASCE. (2017). *ASCE 41-17 - Seismic Evaluation and Retrofit of Existing Buildings*. Reston, Virginia: American Society of Civil Engineers.
- Buker, F., Parr, M., De Francesco, G., Hogan, L.S., Bull, D. K., Elwood, K.J., Liu, A., Sullivan, T.J. (2022). Seismic Damage Observations of Precast Hollow-Core Floors From Two Full-Scale Supper Assembly Tests. *SESOC Journal*, 125-147.
- Francesco G. De, Sullivan T. J. (2021). Experimental loading protocols to evaluate the seismic performance of floor systems. *NZSEE 2021 Annual Conference*. New Zealand Society for Earthquake Engineering.
- Hakuto S, P. R. (1995). *Retrofitting of reinforced concrete moment resisting frames*. Christchurch: Department of Civil Engineering, University of Canterbury.

- Hakuto, S. (1995). *Retrofitting of Reinforced Concrete Moment Resisting Frames*. Christchurch: Department of Civil Engineering, The University of Canterbury.
- Hakuto, S. P. (1999). Effect of deterioration of bond of beam bars passing through interior beam-column joints on flexural strength and ductility. *Structural Journal of American Concrete Institute*, 858-64.
- Hakuto, S., Park, R. and Tanaka, H. (2000). Seismic load tests on interior and exterior beam-column joints with substandard reinforcing details. *Structural Journal of American Concrete Institute*, 11-25.
- NZSEE. (2018). *The Seismic Assessment of Existing building Part C5 - Concrete Buildings*. Wellington: Ministry of Business, Innovation and Employment.
- sProceedings of 12th European Conference on Earthquake Engineering*, (p. 726). London.
- Pampanin, S. M. (2003). Modelling of shear hinge mechanism in poorly detailed RC beam-column joints. *Proceedings of the Concrete Structures in Seismic Regions: fib 2003 Symposium*. Athens: Federation International du Beton.
- Raza, S., Menegon, S. J., Tsang, H. and Wilson, J. L. (2019). Influence of loading history on the drift capacity of limited ductile reinforced concrete columns. *Proceedings of the Australian Earthquake Engineering Society Conference*. Newcastle: AAES.